



# INSTALLATION GUIDELINES FOR EXPANSION JOINT INSTALLATION AND REPAIR

## Overview

Phoscrete is a cementitious concrete repair material with similar properties to the adjacent concrete and is especially well-suited to repair the nosings and headers of many common expansion joints.

## Phoscrete Advantages for Expansion Joints

- **Rapid Return to Service:** In less than one [1] hour, Phoscrete achieves compressive strengths in excess of FHWA guidelines to open a lane to traffic.
- **Same Day Joint Sealant:** As soon as one [1] hour following placement, Silicone and Epoxy adhesives can be applied to Phoscrete, eliminating the need for a second traffic closing to install silicone or compressed foam joint sealants.
- **Tenacious Bond to Concrete and Steel:** Phoscrete bonds chemically and mechanically to sound host concrete for a permanent repair. Phoscrete also bonds to metal.
- **No Cold Joints:** Phoscrete's chemical bond combined with its tensile properties means both the bond between Phoscrete and the host concrete, and the bond between Phoscrete and itself are stronger than the occurring stresses of shrinkage or expansion, and therefore Phoscrete does not delaminate at the bond line.
- **Sandblasting Not Required Prior to Installation of Joint Sealant:** Phoscrete does not bond to plastics including polystyrene (blue board), and urethane-painted forms, so these materials can be cleanly removed after forming the joint nosing.
- **No Primers or Curing Compounds Required:** Phoscrete bonds strong to clean, dry concrete without the need for primers. Phoscrete is traffic or sealant ready without curing compounds.
- **Easy to Use:** Phoscrete has no odor, contains no VOCs, and no free silica on mixing. Phoscrete is mixed, placed and finished using standard concrete tools. Everything cleans up with water.



### **Bridge Joint Repair Site Preparation**

Remove all loose and damaged concrete from the repair area. Phoscrete chemically bonds with the host concrete for a permanent repair, however if the host concrete is not solid and in place, when the host concrete fails, Phoscrete will come off with it.

Remove all non-cementitious previously used repair materials. Phoscrete will not bond to in-place polymer and silicone materials. However, once Phoscrete is in place, silicone and epoxy sealing products bond very well to Phoscrete.

Remove dirt and film from exposed concrete if present. Wet saw cutting can leave a slurry on the bond surface of the host concrete. Jackhammer or sandblast the exposed concrete surface to remove oil and other residues. Phoscrete bonds best to clean dry concrete.

Insure at least a two inch [2"] edge around the repair: Do not leave a feather edge for horizontal or cast-in-place repairs. For best results, saw cut parallel and perpendicular to traffic around the edges of the spall area to limit the number of load-bearing stress points. Remove concrete slurry from cut edges.

Remove loose exposed rust with a wire brush or by sandblasting: Phoscrete is a natural rust-dissolving agent when placed, and sandblasting is not required if all loose exposed rust is removed.

Tack-weld expanded metal when installing Phoscrete onto a horizontal metal surface.

Blow out any remaining dust or standing water from the repair area prior to placing Phoscrete.

Use Bond-Breaking materials such as plastic or blue board to form the edge and to establish uniform expansion joint width.

### **Bridge Joint Repair Nosing Material Placement**

Follow Phoscrete Mixing and Placing Instructions. Most joint header installations are performed mixing and placing Phoscrete in 5 gallon buckets. For larger repairs a mortar mixer may be preferred.

Insure minimum depth and thickness of material placement. For long lasting nosing repairs, install Phoscrete with a minimum depth of 4 inches. Phoscrete can be placed as a nosing material as thin as 2 inches, however hairline cracks due to flexural stress may occur. These cracks do not cause delamination at the bond line. Cracks measured less than 0.2mm are generally not treated, and those greater than 0.2 mm should be sealed with a crack filler.

## Armor Angle Joint Repairs

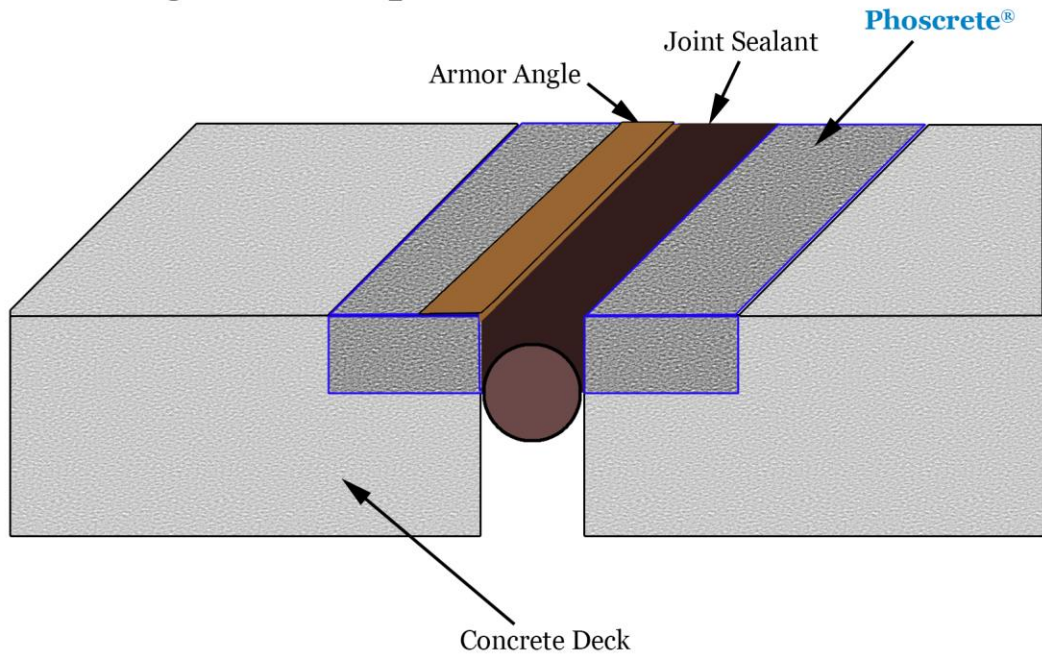

When repairing Bridge Armor Joints, remove the damaged armor joint and damaged concrete and install Phoscrete similar to the "T" Joint repair. In some cases you may keep the armor angle in place and install Phoscrete below the metal to replace the damaged concrete.

## "T" Joint Repairs

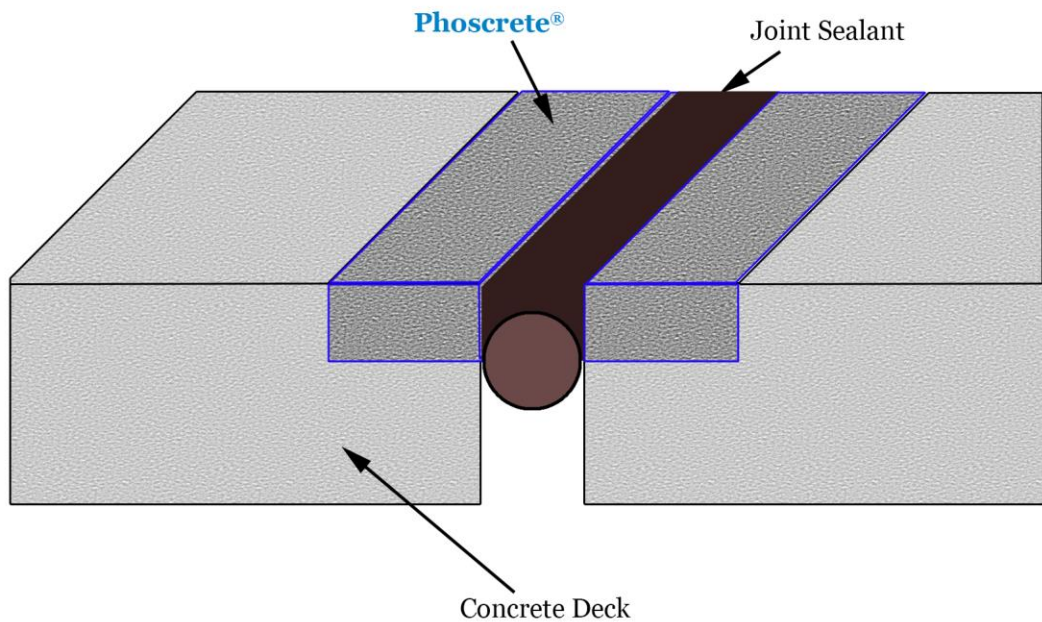

When repairing "T" Joints, saw cut and remove at least 2 inches of concrete at the edges and install Phoscrete.

## Asphalt Overlay Joint Repairs

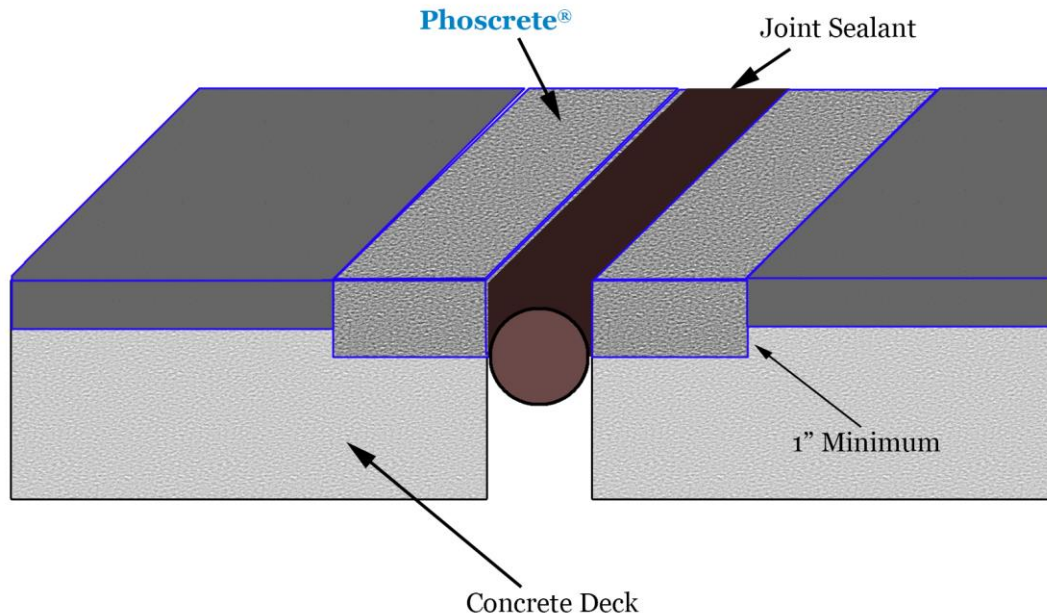

When repairing Asphalt Overlay Joints, saw cut and remove weak and damaged asphalt (minimum 4" width). Sandblast, water blast, or chip out any concrete with petroleum products (asphalt) on the surface at least 1" into the host concrete.

### Bridge Joint Repair Nosing Material Finishing

*Finish or grind a 45° angle at the nosing edge.* Eliminating the sharp edge on the nosing protects the repair material from impact damage.

*Insure the nosing material is level or slightly below the approach slab.* Use an angle grinder or a bump grinder if the nosing material is higher than the approach slab.

### Install Joint Sealant

*Both Silicone sealants and Epoxy adhesives for compressed foam seals can be installed as soon as 1 hour following initial set of Phoscrete.* If you cleanly remove the form board and no oil or release agent is used, sandblasting is not required to adhere the joint seal to Phoscrete. Follow manufacturer's instructions for sealant.

**Contact your Phoscrete Representative if you have any questions or concerns.**